



**Timetable Marathon**

**Time Table 1 HORSE SINGLE \*3**

Obstacles **1234567**

Section	Distance in m	Speed in km/h	Minimum Time	Allowed Time	MaximumTime
A			<b>23:00</b>	<b>25:00</b>	30:00
B	7.850	13,00	<b>33:14</b>	<b>36:14</b>	01:12:28

**Time Table 2 HORSE PAIR \*3**

Obstacles **1234567**

Section	Distance in m	Speed in km/h	Minimum Time	Allowed Time	MaximumTime
A			<b>23:00</b>	<b>25:00</b>	30:00
B	7.850	13,00	<b>33:14</b>	<b>36:14</b>	01:12:28

©Driving Program by Philippe Liénart (BEL) - [driving@horsesdriving.be](mailto:driving@horsesdriving.be)

# CAI 3\* Le Pin au Haras

Maraton Phase B 7850 m



Haras national du Pin  
PÔLE DE SPORTS EQUESTRES

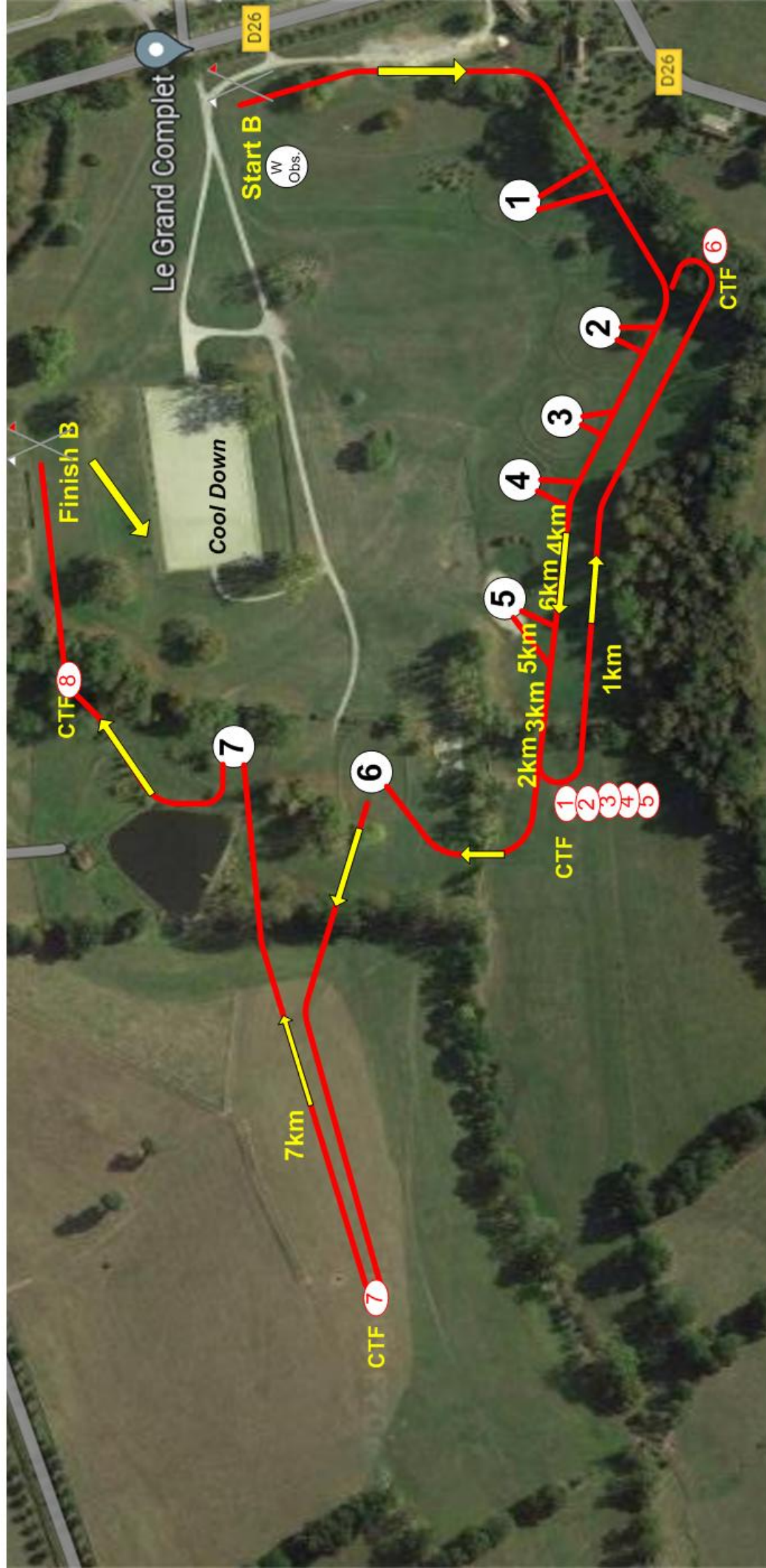

# CAI 3\* Le Pin au Haras



# 1

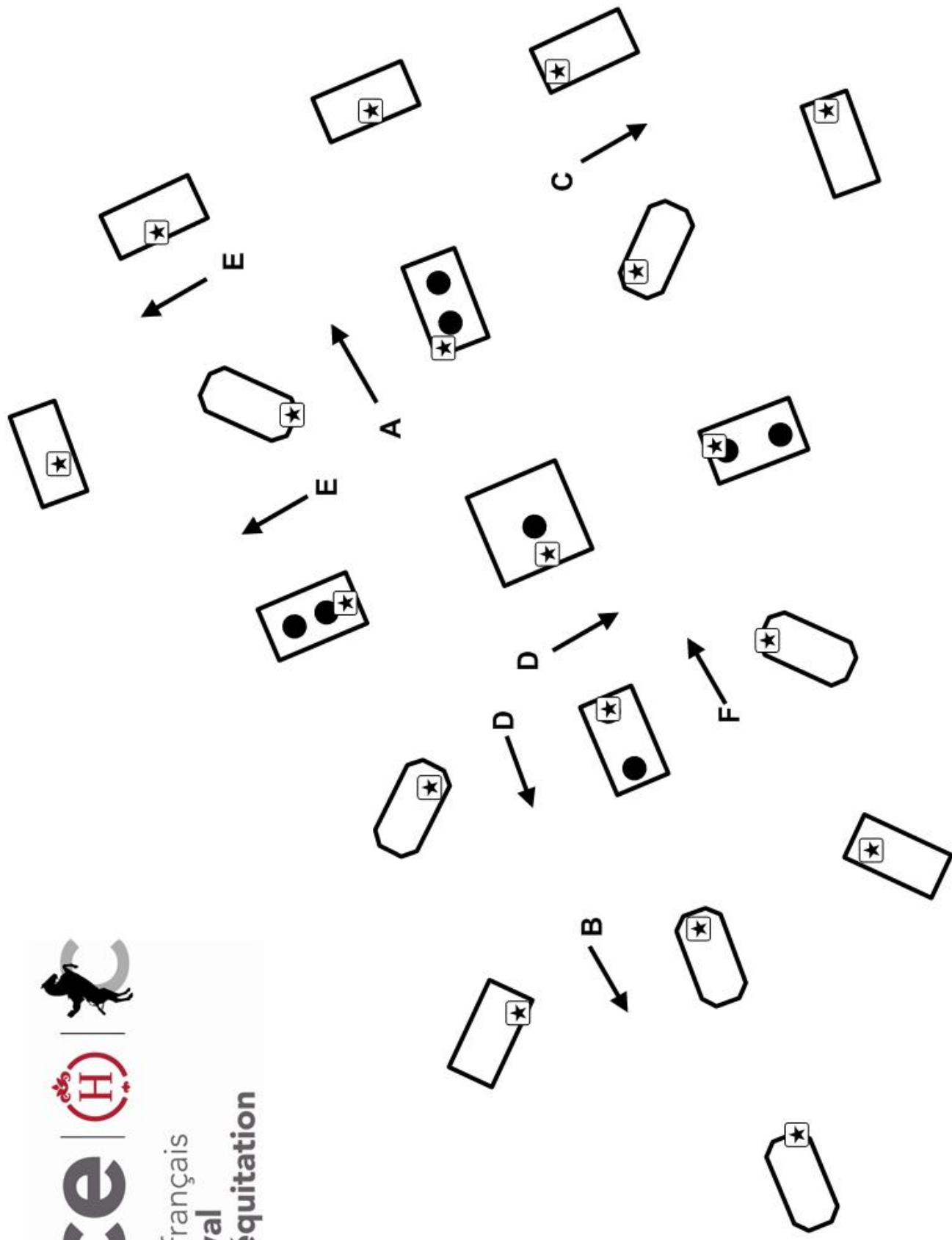

In / Out

# CAI 3\* Le Pin au Haras

## Conseil Departemental de l'Orne



# 2

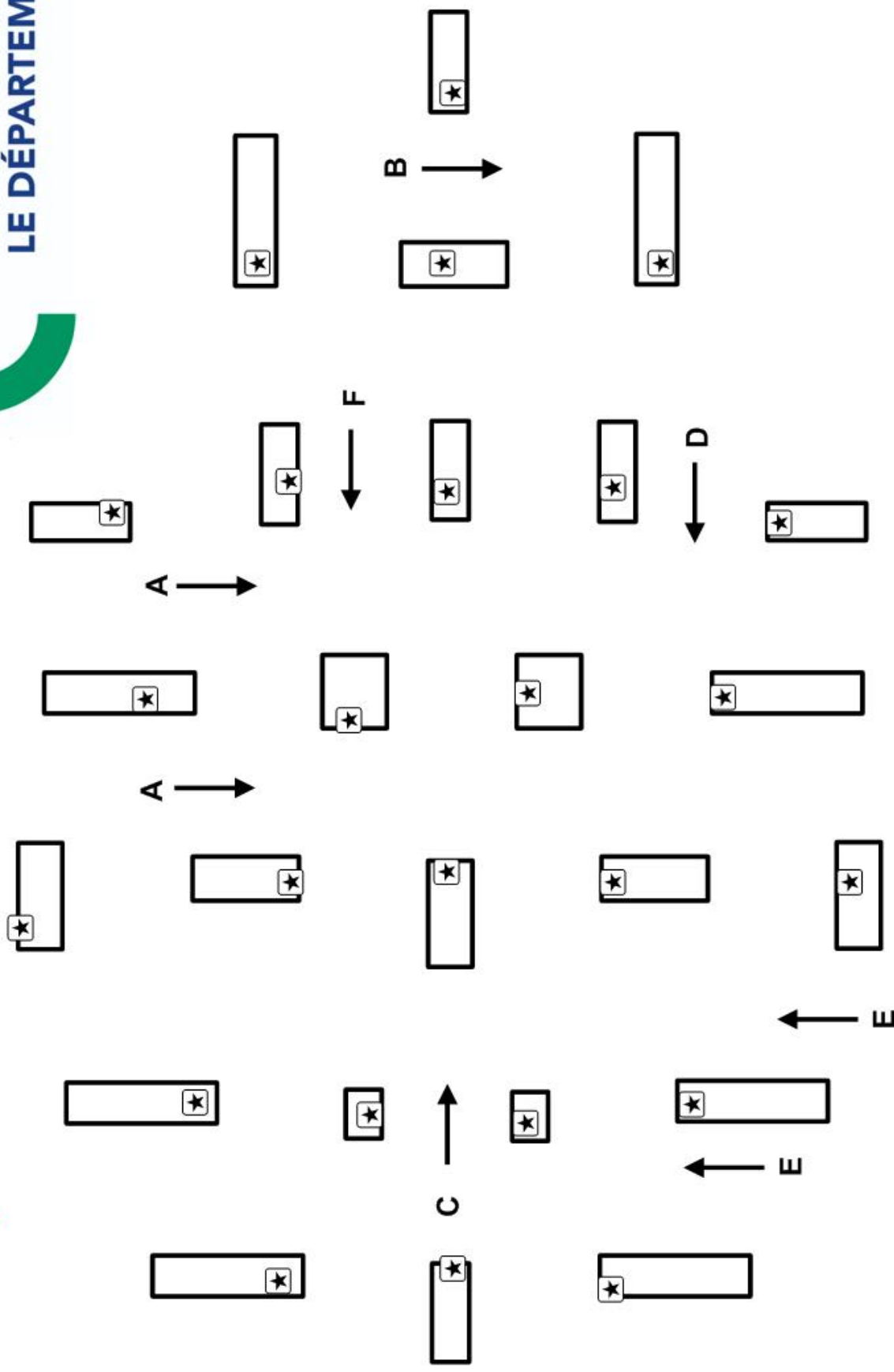

# CAI 3\* Le Pin au Haras



# 3

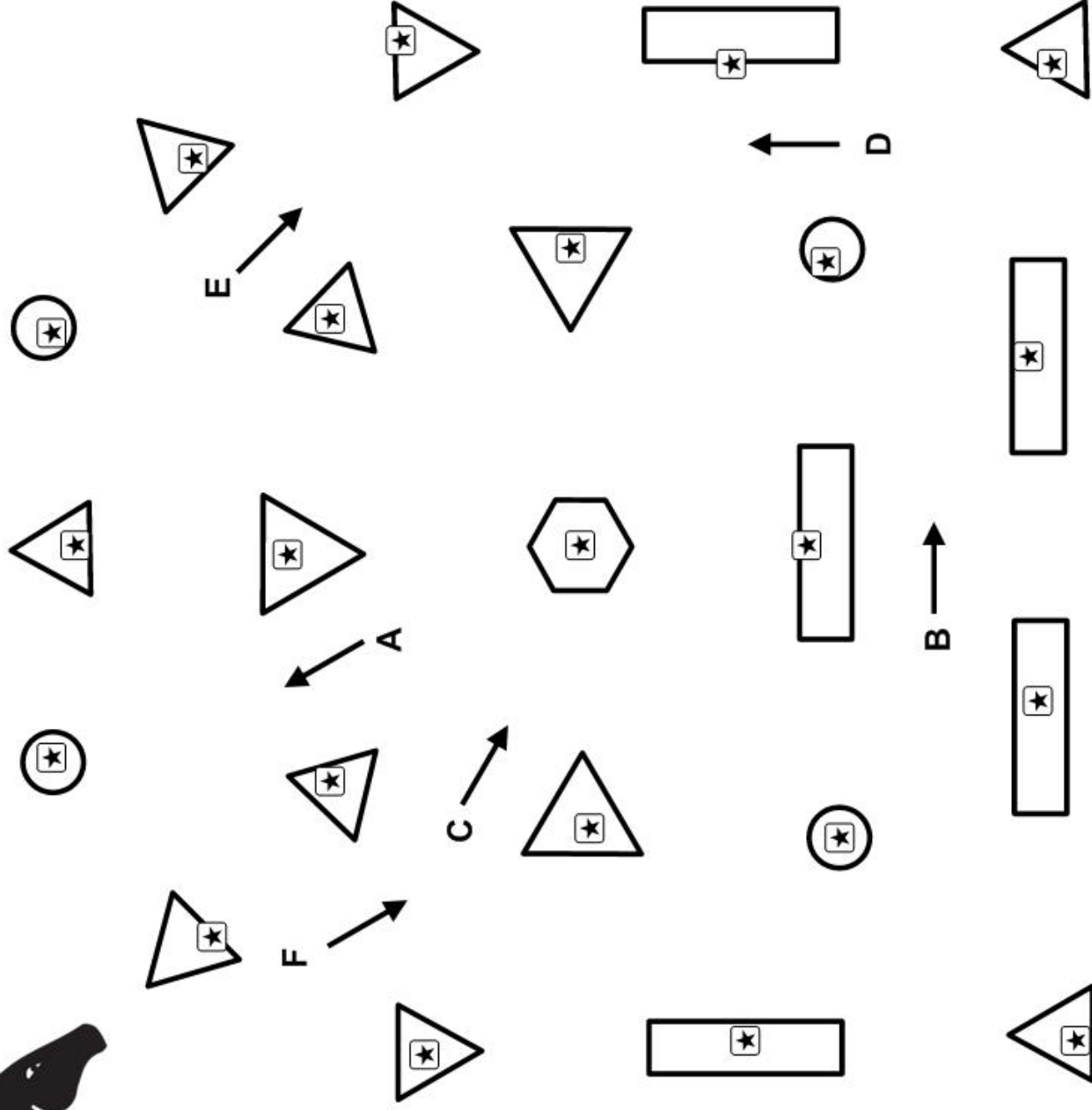

In / Out

Knock down 22

# CAI 3\* Le Pin au Haras



Haras national du Pin

PÔLE DE SPORTS EQUESTRES

# 4

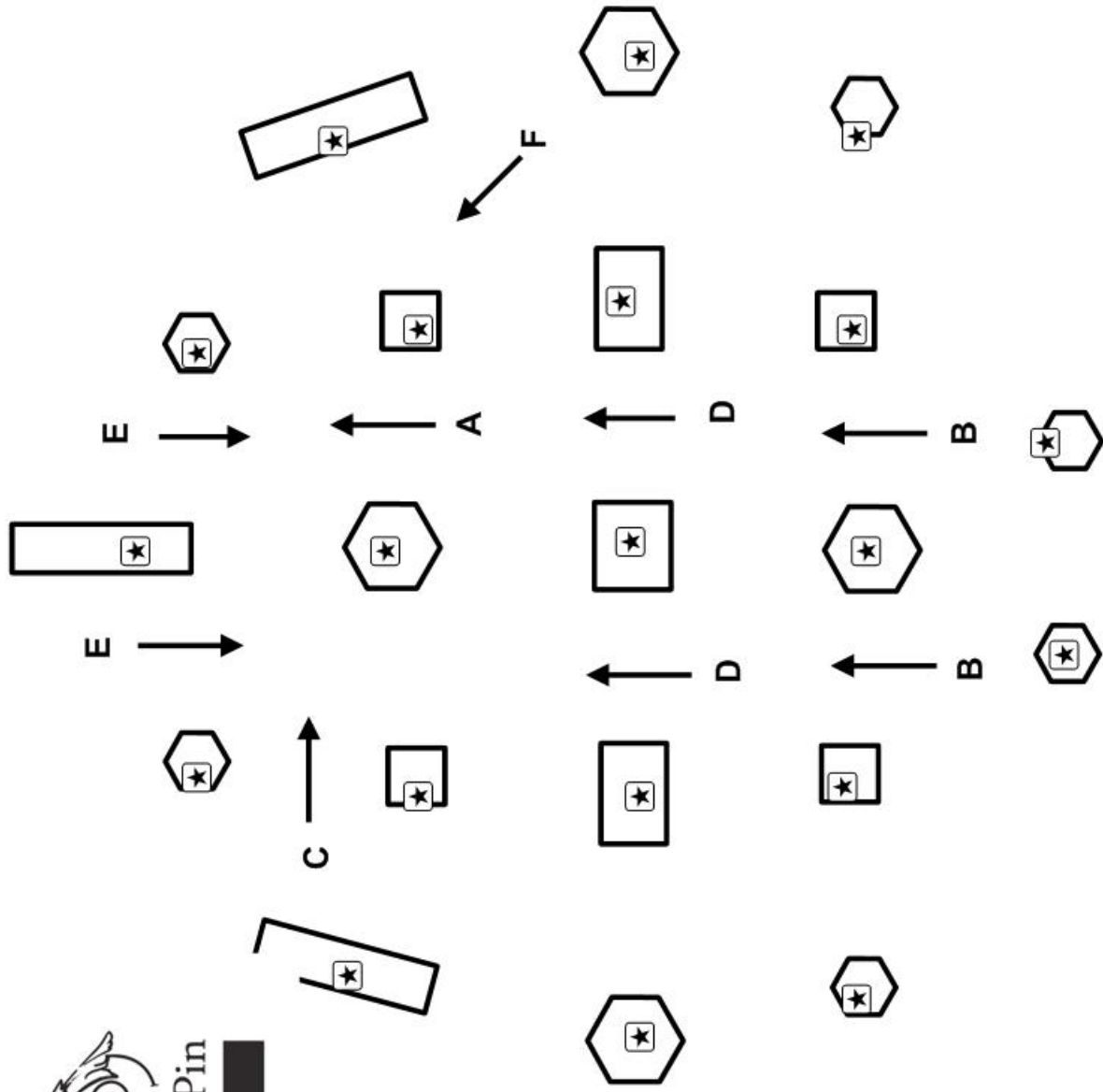

In / Out

Knock down 20

# CAI 3\* Le Pin au Haras

# 5



RÉGION  
NORMANDIE

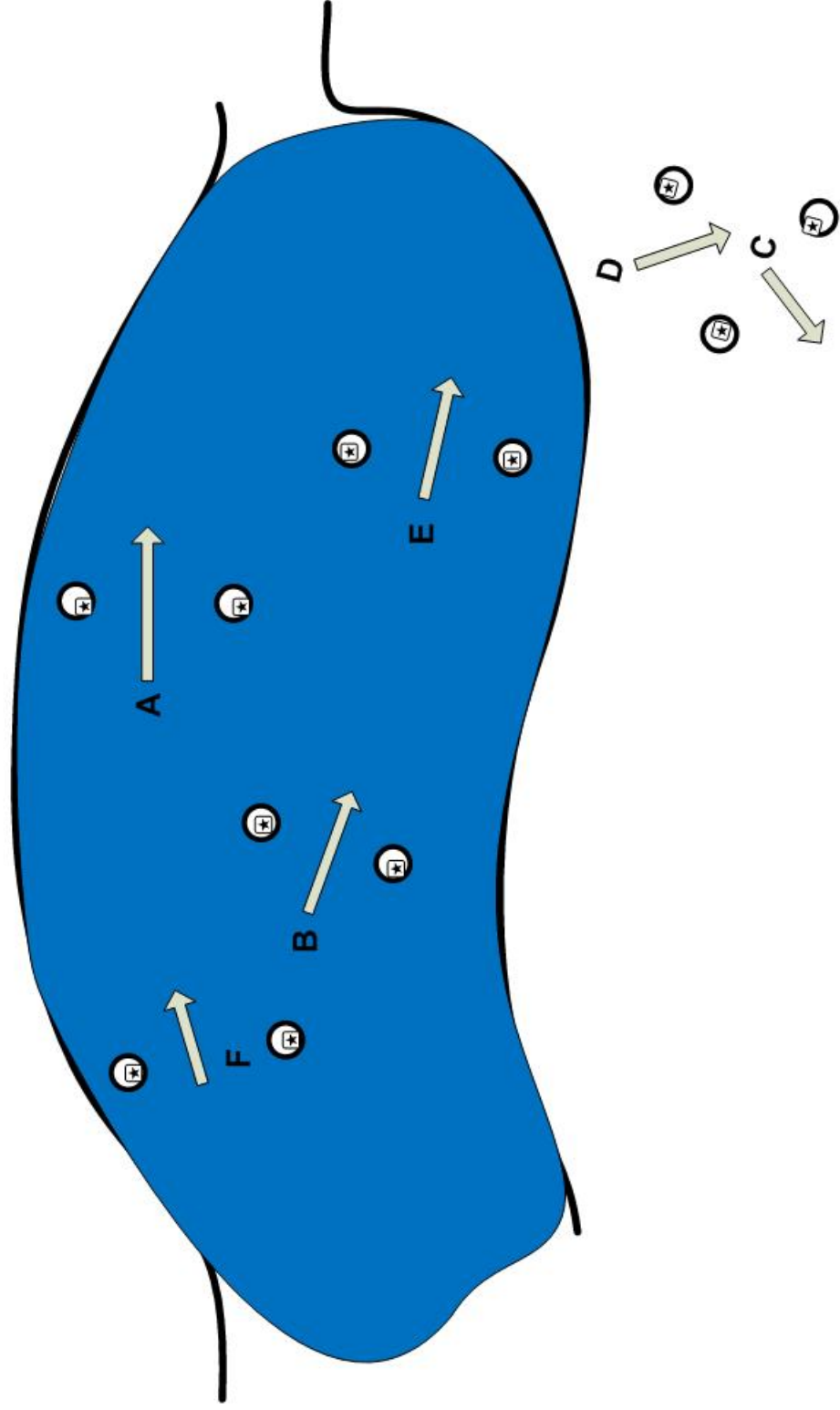

Knock down 11

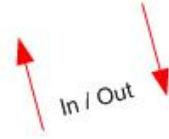
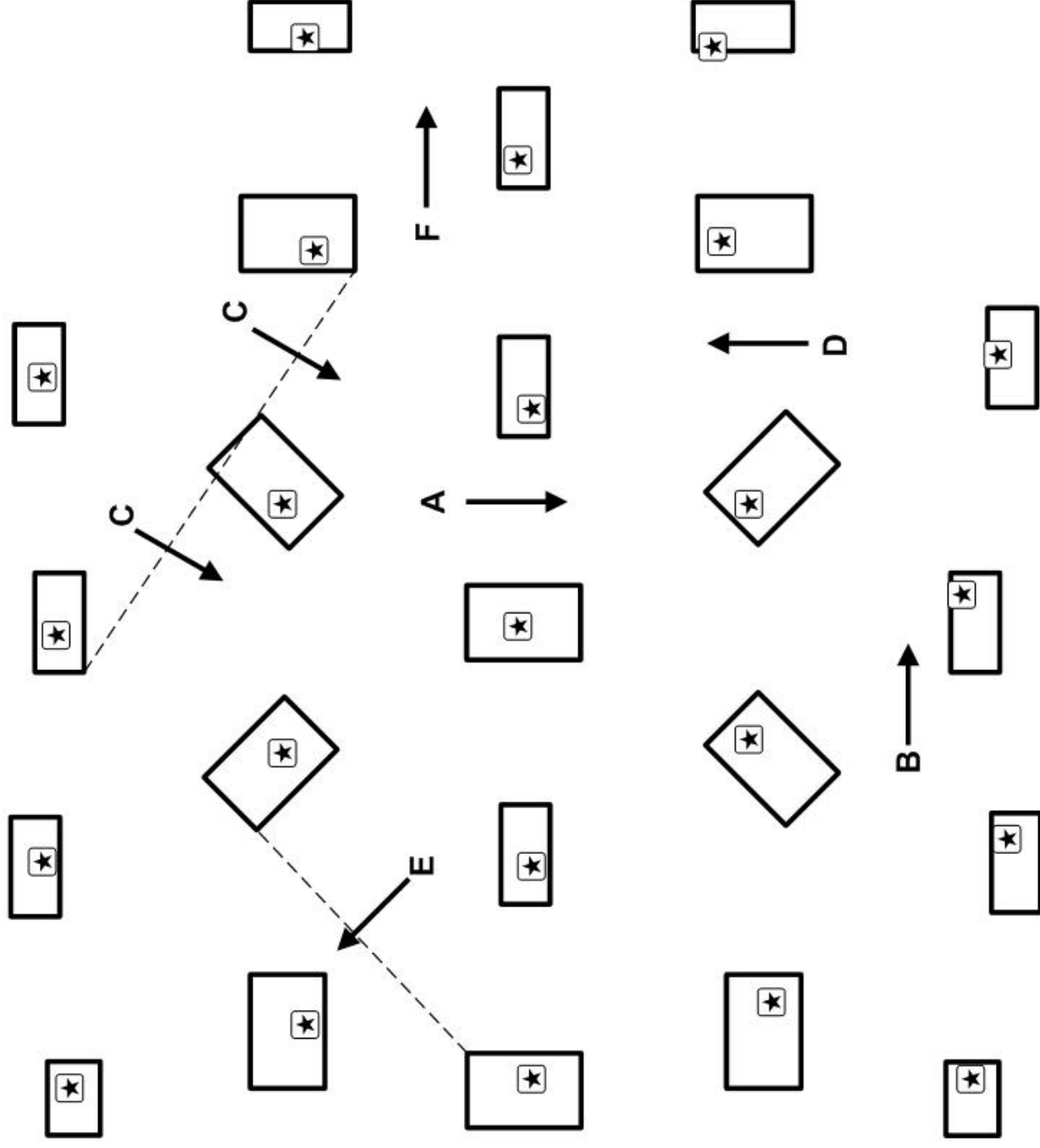



# CAI 3\* Le Pin au Haras



Argentan  
INTERCOM

7

